

124 SYLVANIA PLACE  
SO. PLAINFIELD, NJ 07080-9998  
VISIT OUR WEBSITE  
WWW.LIFTEC.COM



CUSTOMER SERVICE HOTLINE  
1-800-872-4924



**ISP-11**

**THE WAVE BREAKER!**

**MORE THAN 18.5 MILES ON ONE  
BATTERY CHARGE!**

**\$22,595.00**

Includes Gate Auto Lock Option  
**Delivered**



The ISP-11 features an anchoring point on the back of the chassis where a hook can be fastened to a tow trailer carrying up to 440 lbs. Loading platform at maximum height corresponds to the column height. The column, in special extruded aluminum alloy, is completely without any need of maintenance. Acceleration of forward/backward movement is proportional and positioned near the basket raising and lowering button, to enable these movements even during forward movement. All systems are operable without having to move the hand from the accelerator, for maximum operator comfort. Safety position with double sensor pedal and left hand sensor allow activation of the functions. These safety devices serve to guarantee the stable position of the operator, with both hands on the controls before these become activated. Material tray is electrically operated by a button in the upper control box.



"like" us on



follow us on

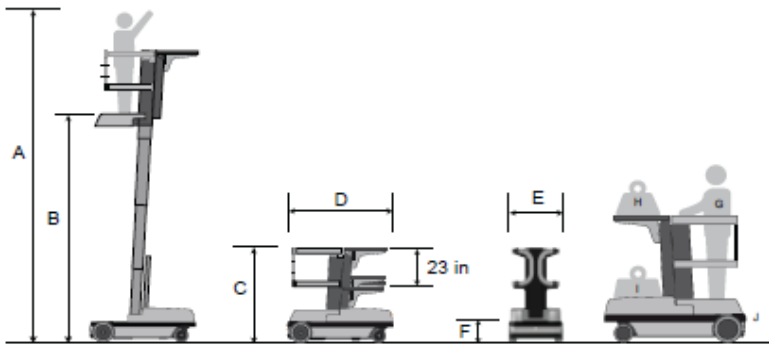

**ZERO Inside  
Turning Radius  
and 57\"/>**

<b>TECHNICAL DATA</b>		
<b>A</b>	<b>Max. Working Height</b>	17'6"
<b>B</b>	<b>Max Platform Height (Upright fully extended)</b>	11'
<b>C</b>	<b>Height Stowed</b>	56.7"
<b>D</b>	<b>Length Stowed</b>	57"
<b>E</b>	<b>Width</b>	31.8"
<b>F</b>	<b>Entry Step</b>	14"
<b>Occupants</b>		1
<b>Unit Gross Weight (Unoccupied)</b>		1,499 lbs
<b>Drive Speed Stowed</b>		3.54 mph
<b>Drive Speed Raised</b>		0.54 mph
<b>Gradeability</b>		35%
<b>Raise/Lower Speed</b>		18/14 sec
<b>Driving System</b>		Two-Handed Proportional
<b>Tires</b>		Full Non Marking
<b>Tilt Sensor</b>		Standard
<b>Inside Turning Radius</b>		Zero
<b>Outside Turning Radius</b>		57"
<b>CAPACITIES</b>		
<b>G</b>	<b>Operator's Bay Capacity</b>	287 lbs
<b>H</b>	<b>Materials Tray Capacity</b>	198.41 lbs
<b>I</b>	<b>Transport Hood Tray Capacity</b>	249.12 lbs
<b>J</b>	<b>Trailer Tow Capacity</b>	440 lbs
<b>POWER</b>		
<b>Batteries</b>		4 - 6V 245AH
<b>Power</b>		24 V c.c.
<b>Load Network Power</b>		220 V c.a.
<b>Duty Cycle-Drive (On one charge)</b>		18.5 Miles

### AEUP® PLATINUM WARRANTY™

The **BEST** warranty in the industry:  
**10 YEARS** on the mast and cylinder  
**5 YEARS** on all components  
**1 YEAR** on batteries, not prorated

### Features:

- No more chains to be inspected every year.
- No more grease on the mast.
- No maintenance required.
- Futuristic canopies are ergonomically designed, made of resilient carbon
- Completely sealed to enhance protection against shocks and damages caused by debris falling from above.

### OPTIONS:

- Holder for Bar Code Scanner
- Audible alarm for gate when platform is elevated and open
- Automatic locking system for gate when platform is elevated
- Updated Steering Actuators

